

Attachment D  
3.4 Garage Design Standards

Attached Garage: Front-Facing

Garage Setback Exception

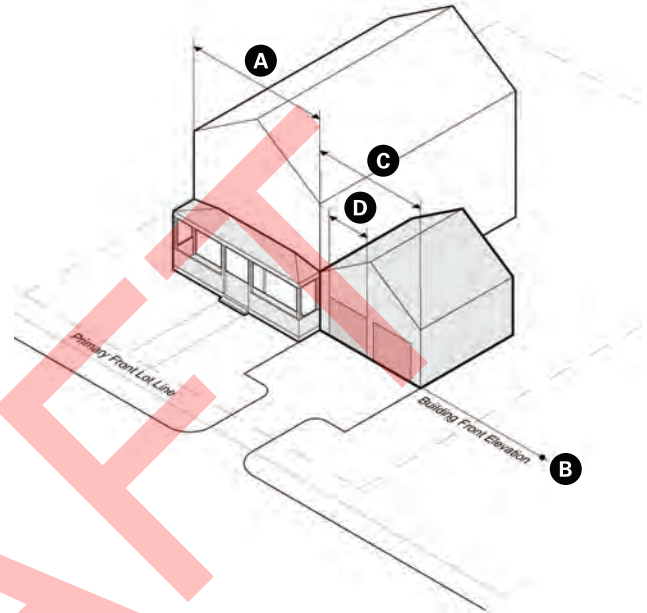
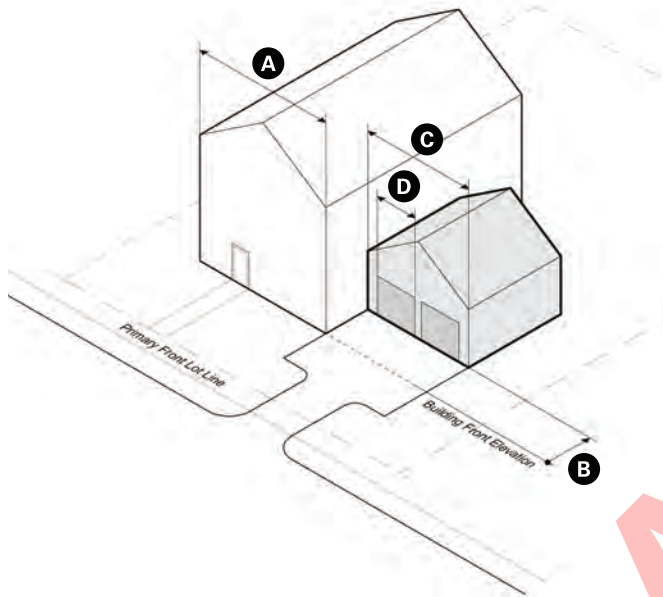

Principal Building	min	max
<b>A</b> Front Elevation	--	--
<b>Garage Setbacks</b>		
<b>B</b> Distance from Building Front Elevation	8 ft	--
Exceptions: A Front Facing Garage may be in alignment with the Building Front Elevation with a Porch meeting the requirements according to Sec. 3.3.2.C.	0 ft	--
<b>Garage Dimensions</b>		
<b>C</b> Garage width	--	50% of total Front Elevation
<b>D</b> Width of individual Garage Door	--	9 ft

Attachment D  
3.4 Garage Design Standards

Attached Garage: Side-Facing

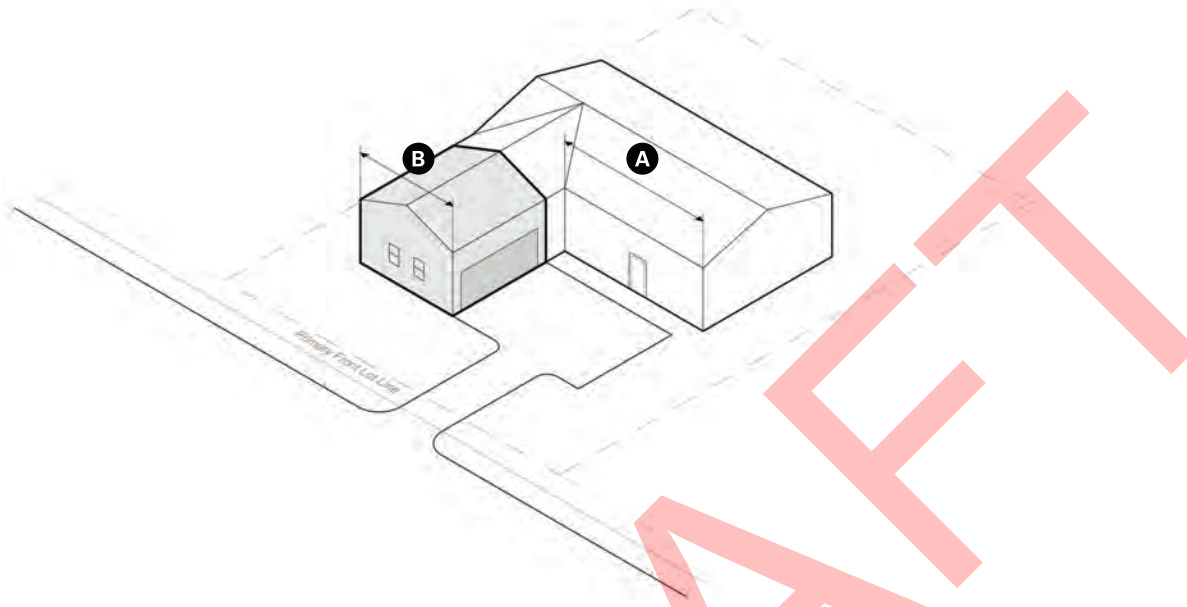

Principal Building	min	max
<b>A</b> Front Elevation	--	--
Garage		
<b>B</b> Width of Garage Wall facing street	--	50% of total front elevation
Fenestration on Garage Wall facing street	20%	50%

Attachment D

3.7 Parking Requirements in the Residence Districts

E. Driveway Access

Lot with eight residential units or less

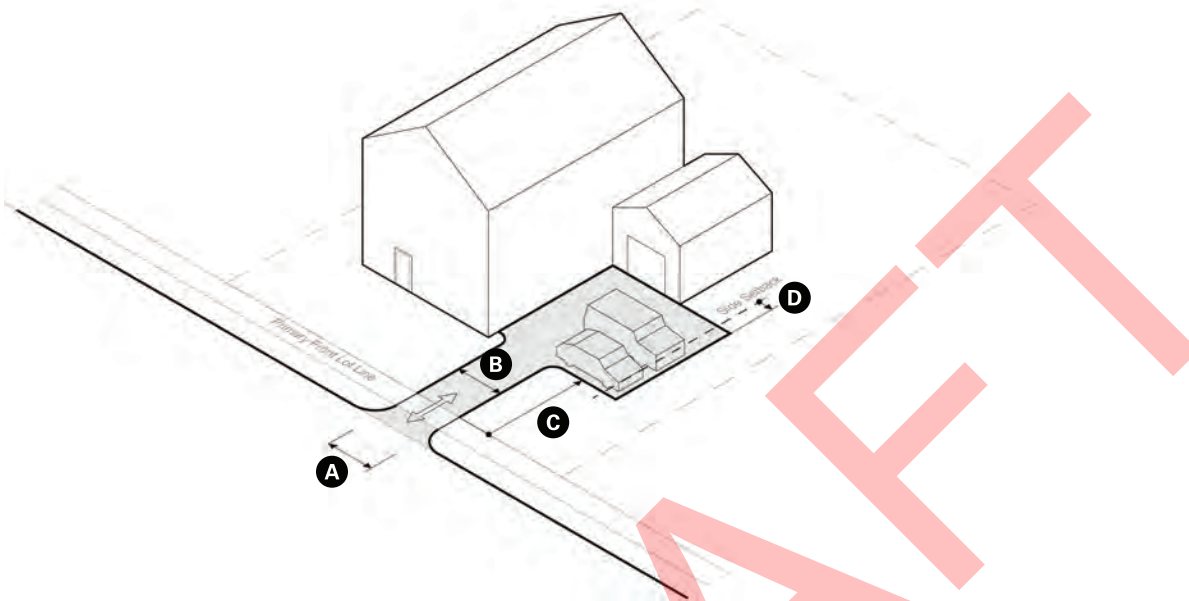

Curb Cut Dimensions	min	max
<b>A</b> Width	--	12 ft
Number of Curb Cuts	--	two curb cuts are permitted on a lot with a residential Building Type with two-units or more
Distance between Curb Cuts	35 ft	--

Driveway Dimensions	min	max
<b>B</b> Width	--	10 ft
<b>C</b> Distance that the driveway must conform to width limits, measured from the lot line where the driveway is accessed		
R1 and R2	10 ft	--
R3, R4, and N	5 ft	--
<b>D</b> Side Setback Encroachment	--	3 ft

Parking Stalls	
Location	2 parking stalls may be located in the side setback area. No parking stall may be located between the building front elevation and the street

Attachment D

3.7 Parking Requirements in the Residence Districts

E. Driveway Access

Lot with nine residential units or more

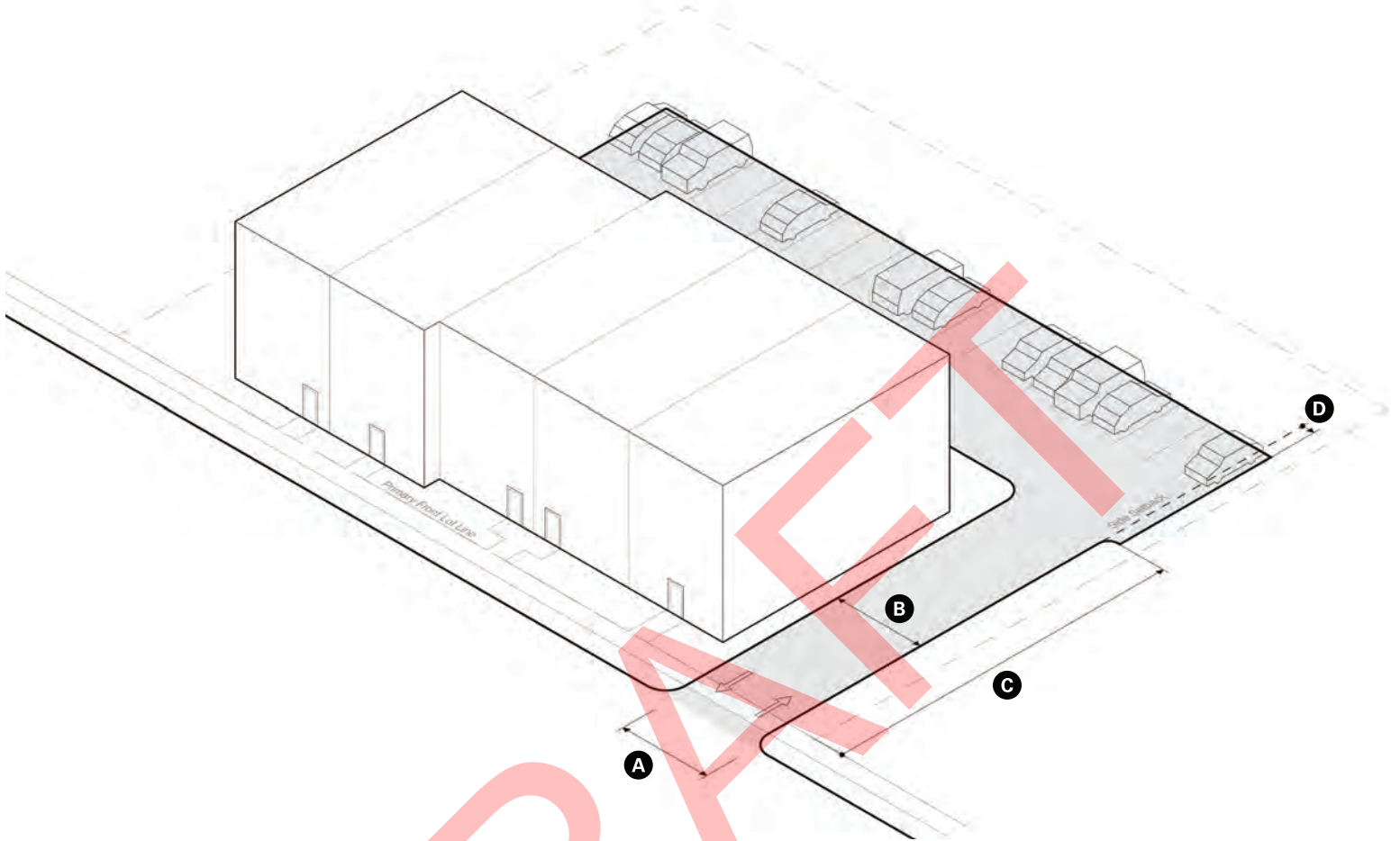

Curb Cut Dimensions	min	max
<b>A</b> Width	--	22 ft
Number of Curb Cuts	--	two
Distance between Curb Cuts	35 ft	--

Driveway Dimensions	min	max
<b>B</b> Width	--	20 ft
<b>C</b> Distance that the driveway must conform to width limits, measured from the lot line where the driveway is accessed		
R1 and R2	10 ft	--
R3, R4, and N	5 ft	--
<b>D</b> Side Setback Encroachment	--	3 ft

Parking Stalls	
Location	2 parking stalls may be located in the side setback area. No parking stall may be located between the building front elevation and the street